

## Alarko Carrier Gebze Plant Natural Resources Consumption SCADA System

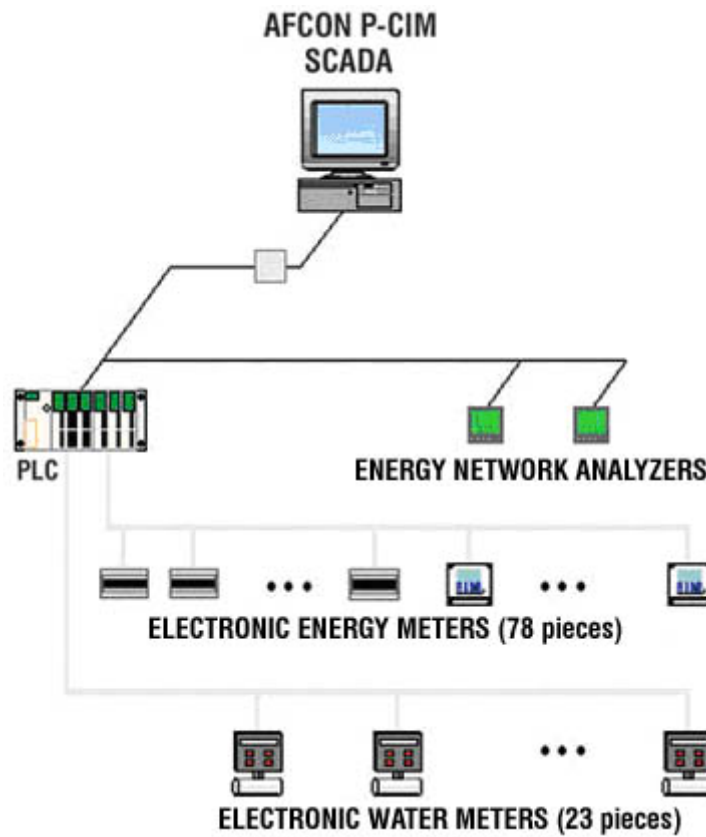

### **Client**

Alarko Carrier

### **Project Scope**

The electric and water consumptions of the plant are reported daily and monthly for each department with the SCADA application in one control center.

### **Start-up**

2004

# Our Projects

## Plant

Alarko Carrier Gebze Plant (ACGK), has a 36.800 m<sup>2</sup> production building on a area of 60.500 m<sup>2</sup> at Gebze Industrial Zone. Certified with ISO 9001, main items in production with Carrier brand are HVAC supplies, fan coils, burners, cooling units, furnace supplies and circulation pumps. There are 650 employees in production lines, 324 employees in management and sales departments and 22 employees in R&D department.



## Project

Totally 78 electronic energy meters and 23 electronic water meters are installed and connected to the PLC. Pulse outputs of these meters are being counted inside the PLC and reported with the SCADA application. Daily and monthly reports are generated. Also reports between two dates which are entered by the operator are available. With reporting option for historical values, it is possible to go back to the first record captured by the system. After realization of the project, the consumptions of the plant are disciplined.

